



WHEN MOTION COUNTS

image **TEMA Classic**

Contact

Image Systems Nordic AB

Snickaregatan 40, 582 26

Linköping, Sweden

sales@imagesystems.se

Note

For TEMA T2020

and more recent versions

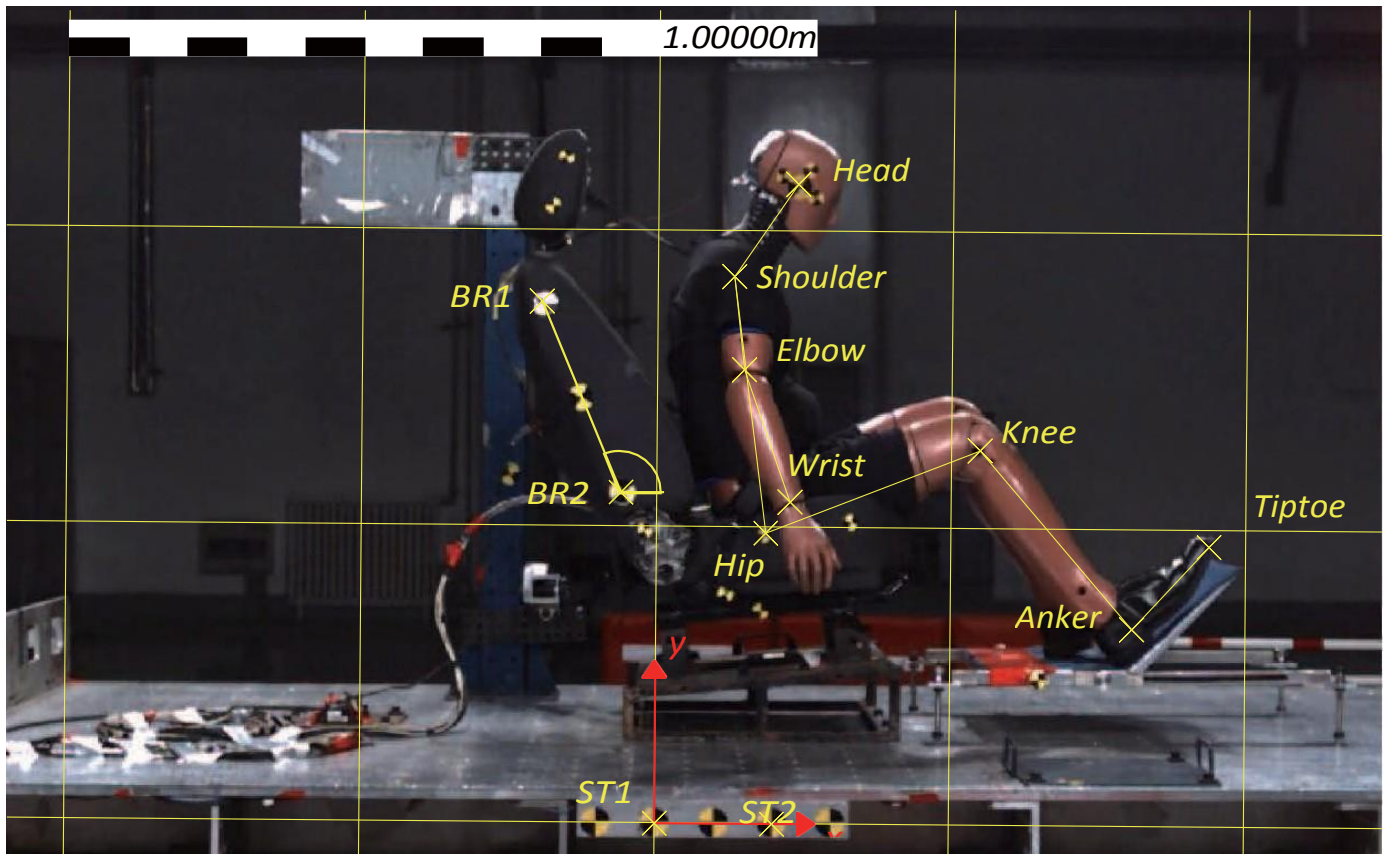

TEMA Classic is the market-leading software suite for advanced Motion Analysis tests in research and industry.

Thanks to its high accuracy, modular structure, calculation speed and intuitive user interface - TEMA Classic is used by professionals across the globe in a wide range of applications from drop testing smart phones

to improving sport performances or even optimizing processes in the automotive and aeronautical industry through the tracking of trajectories.

TEMA Classic has a wide library of tracking algorithms included in its default package which allows to track almost any kind of objects in any situation. The algorithms are based on pattern recognition and/or levels of grey and allow tracking with sub-pixel accuracy.

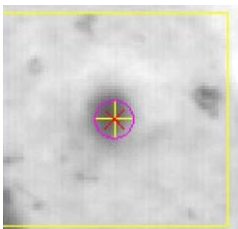

CORRELATION

Looks in each successive image for the area that correlates best with the pattern defined in the first image.

This method is applicable to most cases, as it doesn't require a marker.

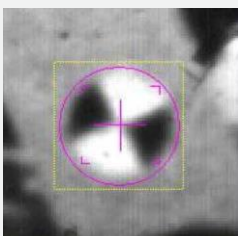

QUADRANT

Automatically locks to the centre of the quadrant target and is invariant to rotation, scaling and change in light conditions. It provides the position of the centre of the quadrant target as well as its angle in regards to a given orientation. Quadrant targets are recommended for applications with high demand on accuracy and automation.

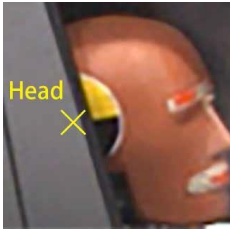

VIRTUAL POINTS

The Virtual algorithm triangulates the position of a point (visible or masked in the sequence) by using the tracked position of at least 3 other points from the same rigid object and which are visible in the sequence. The points must be part of the same group to apply the virtual algorithm.

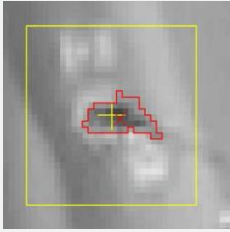

CENTRE OF GRAVITY

Find the centre of gravity of a closed contour or a contrasted marker/object with the background. The detection is based on level of grays in the image and threshold can be defined automatically for dark or bright objects or manually using sliders on a 0-255 colour scale. The centre of gravity algorithm is not sensitive to scaling.

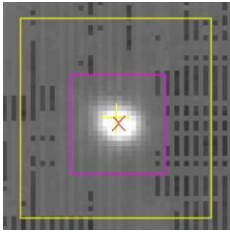

CIRCULAR SYMMETRY

Finds the symmetry centre of the image within the search area.

It is applicable to concentric circles, spokes on a bicycle wheel or combinations thereof.

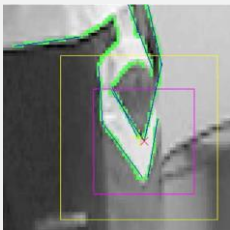

INTERSECTION

Tracks intersection points (corners) on any object shape.

The algorithm detects the intersection of contrasted edges by extrapolating straight lines along those edges and fills gaps if necessary.

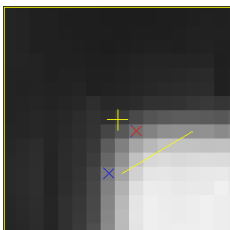

CORNER CONTOUR

The Corner Contour Tracker can detect edges and find corners along these edges.

One corner will be selected as the track point



MOUSE TRACKER

In the case any form of automatic tracking would fail due to poor quality of images, the operator can manually track the object of interest in a sequence using a mouse pointer.

The playback speed can be adjusted to help the process.



Checked Lens Caliboard

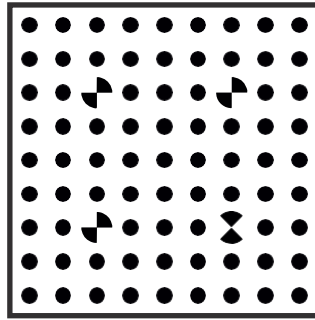

Smart Lens Caliboard

Available in TEMA Pro for automatic lens calibration

The Planar Target Calibration Board consists of a rigid two dimensional flat board with evenly distributed markers.

The workflow is rather simple:

1. Capture a sequence of images with different orientations of the board;
2. Identify the 4 quadrant markers on the checker board in each image or track them in the case of a continuous sequence
3. Inspect results of the lens calibration. A distortion table is available in addition to the summary of all calibrated parameters with their accuracy.

PARAMETERS

Typical parameters that can be calibrated

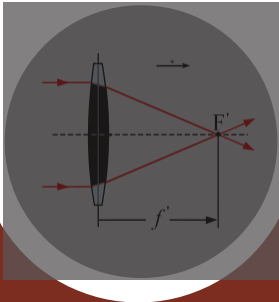

Focal Length

The focal length is measured in pixels.

As the focal length varies with focus settings to get the sharpest images in different scenery, the calculated value may differ from the nominal value specified by the lens manufacturer.

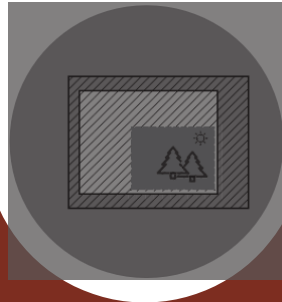

Principal Point

The principal point represents the point of the image where the distortion is centered and corresponds to the optical axis of the camera. In the case the resolution was cropped to increase frame rate, the principal point might be different from the centre of the image.



Aspect Ratio

Pixel Aspect Ratio (PAR). The "squareness" of pixels, normally "1:1".

In certain older videos, the image is stretched to fit the screen. A rendering of this format can result in a non-square-pixel.

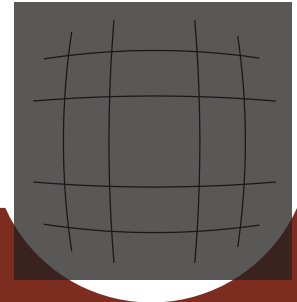

Lens Distortion

Although distortion can be irregular or follow many patterns, the most commonly encountered distortions are radially symmetric.

Depending on lens quality and focal length, distortion may be significant.

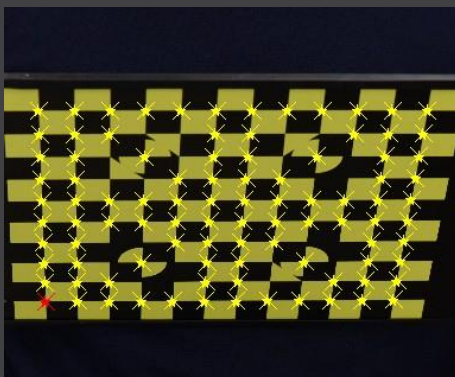

Calibration Status			
Calibration Successful			
Calibrated Parameters			
Parameter	Value	Accuracy (std dev)	Unit
f	23271.13	24.44	pixels
f (length units)	113.56	0.11927	mm
Principal point x	3212.00	37.13	pixels
Principal point y	2440.80	30.87	pixels
Aspect ratio	0.99955	0.00014160	
R0	23140.00	0.00	pixels
A1	-0.19664	0.062301	
A2	-1.7674	8.2740	
A3	83.000	323.30	
B1	0.0024151	0.00027921	
B2	-0.0031458	0.00029947	
Residuals			
Mean Residual =	1.13 pixels	Max Residual =	5.92 pixels
Standard Deviation =	0.80 pixels		
Distortion Table			

INSPECT RESULTS

- Residuals for Each Frame
- Calculated Focal Length
- Impact of Lens Distortion
- Coefficient for Radial Distortion Correction
- Point with Max Residual

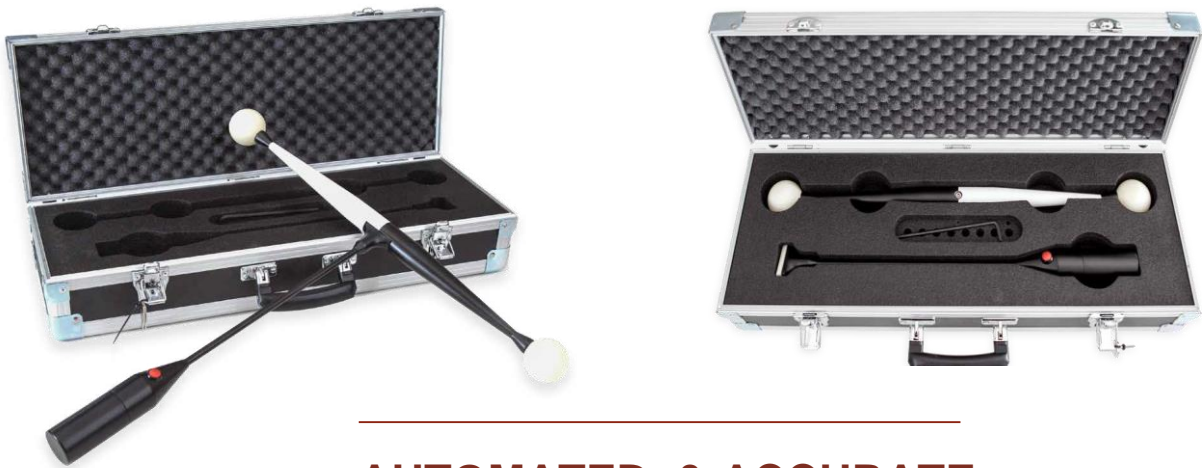

AUTOMATED & ACCURATE

Simultaneously calibrate the orientation, distortion and focal length of all cameras on the scene by tracking a single sequence of a calibrated illuminated tool



Complete Solution

- Calibrated carbon fiber tube
- 3D printed LED bulbs
- Battery power
- Allen key & screw assembly
- Portable case
- Flexible measurement volumes from 1m×1m×1m to 10m×10m×3m



Calibration Procedure

1. Position cameras
 - 30°~150° acceptable
 - 90° optimal
2. Record calibration images
 - Maximize contrast
 - Avoid motion blur
 - Regular room lighting
3. Record test images
4. Analyze test 3D results



Key Benefits

- Fast and automated with accuracy report
- Unlimited camera numbers and brands
- Calibrate all cameras simultaneously with
 - Focal Length
 - Lens Distortion
 - Camera Orientation (x, y, z, roll, pitch, yaw)

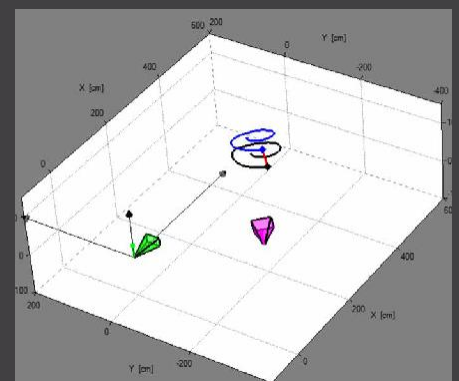
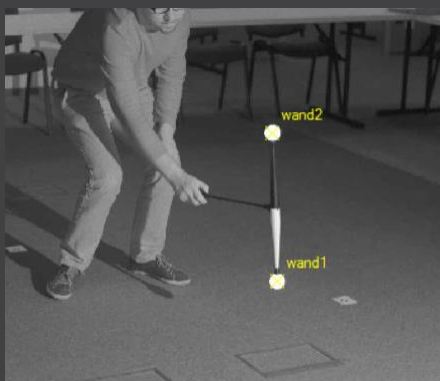

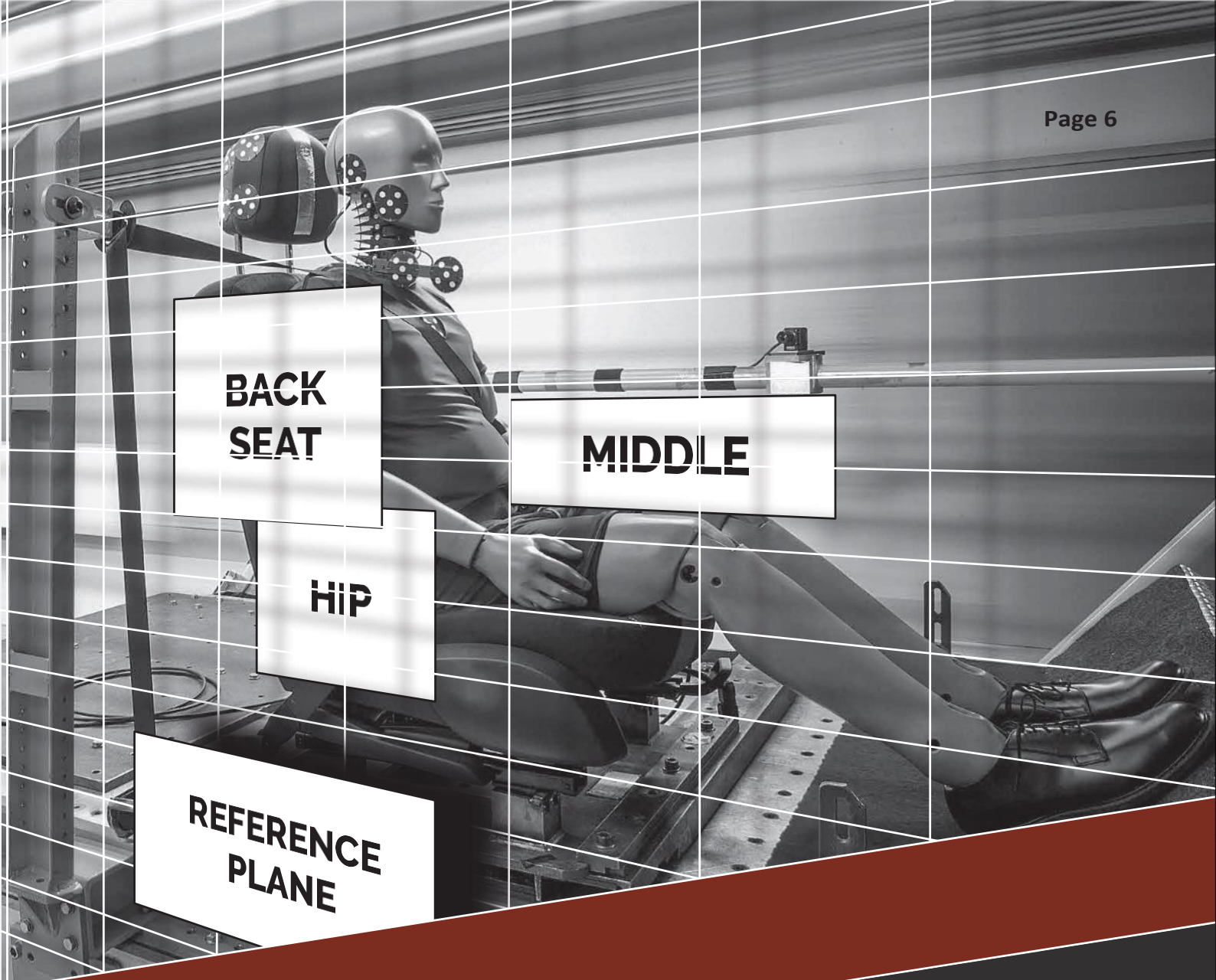

TEMA Classic2D

Sled Crash Test is a cost-effective way of testing components such as airbags, dummies and seat belts in automotive field. The movements of a dummy and the seat on the sled will be captured by onboard and/or offboard high-speed cameras.

TEMA is the most accurate tool, where you can dynamically handle object tracking, multiple parallel motion planes and perspective correction (2.5D) during SLED tests.

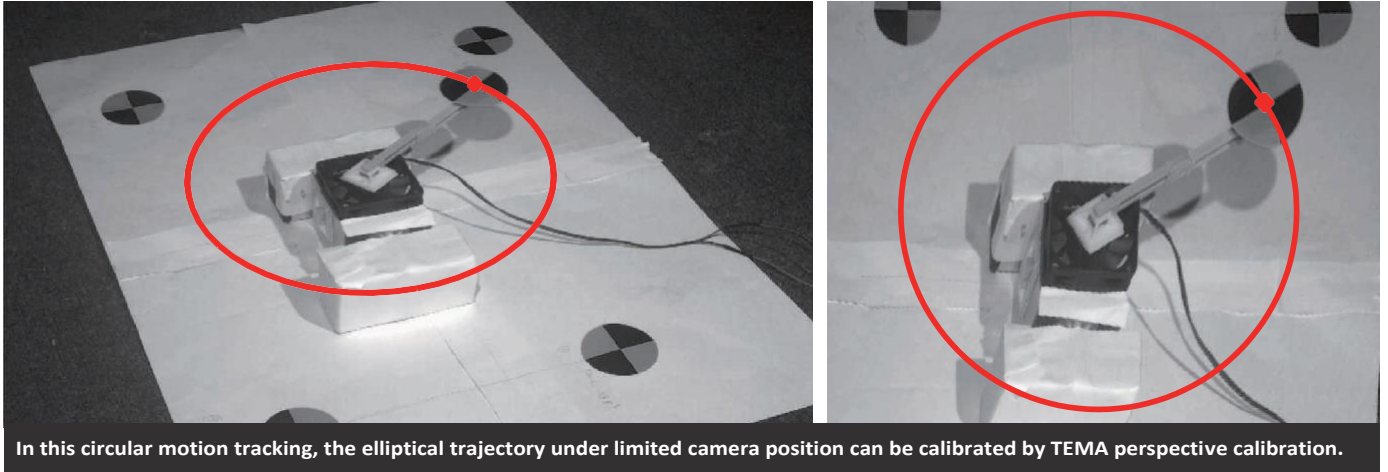

2D tracking is the basic functionality of TEMA. Tracking a marker or an object in the image sequence using any algorithm from the available library will produce 2D pixel coordinates. Those 2D coordinates can then be used to calculate velocity, acceleration, distances and angles. They will also serve for basis when dealing with 3D or 6DoF calculations.

A wide variety of time synchronized diagrams and tables allow to display tracked data versus time, per frame or even in the frequency domain.



Dynamic Coordinate System

The user can define his own coordinate system using points tracked on the image. This coordinate system can be static as well as dynamic.

In this case, the position and orientation of the coordinate system is recalculated at every frame allowing to compensate for vibration of the camera in 2D or analyze a relative movement between two objects.

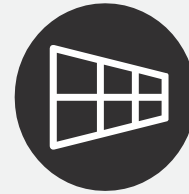

Perspective Correction (2.5D)

In case the camera is not perpendicular to the motion plane, the perspective bias will impact the quality of the end result.

The TEMA software offers several methods to calculate the azimuth and elevation angles of the camera to the motion plane and compensate for this non perpendicularity.



Multiple-Parallel Planes

In case the points are at different depths in the image, but still moving parallel to the same motion plane, TEMA can compensate by entering the known depth for the points, reducing errors resulting from depth scaling issues

Perspective Correction (2.5D) can be used in addition to this function.



Exportable 2D Data

Position, velocity, acceleration, distance and angle data (raw or filtered) can be exported in any coordinate system (default or user defined) as a function of time or per frame in various formats.

Camera views, image diagrams or combination of diagrams can be exported as animated sequences with title slates, skips and text notes for easy reporting in classic image/video formats.

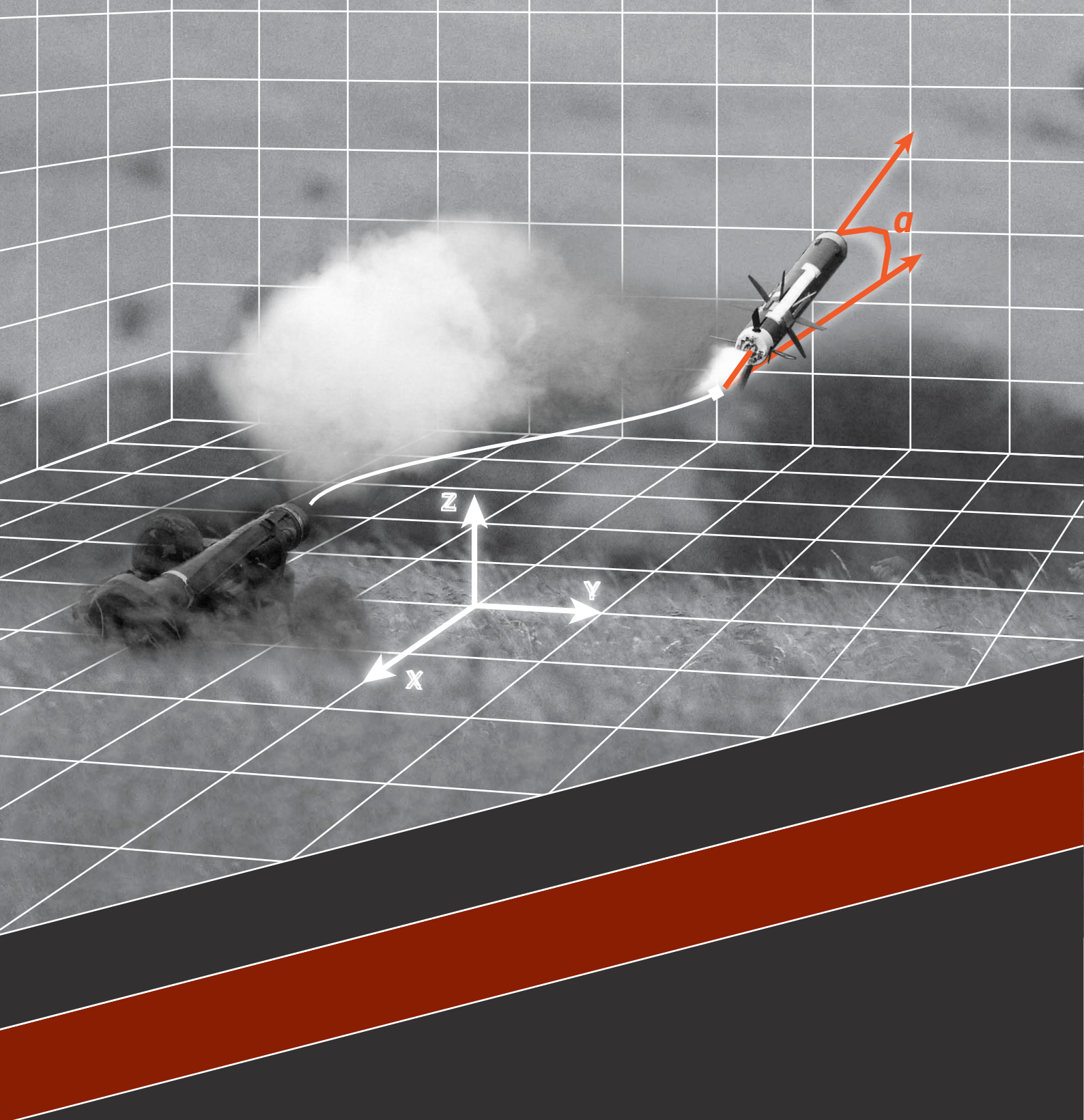
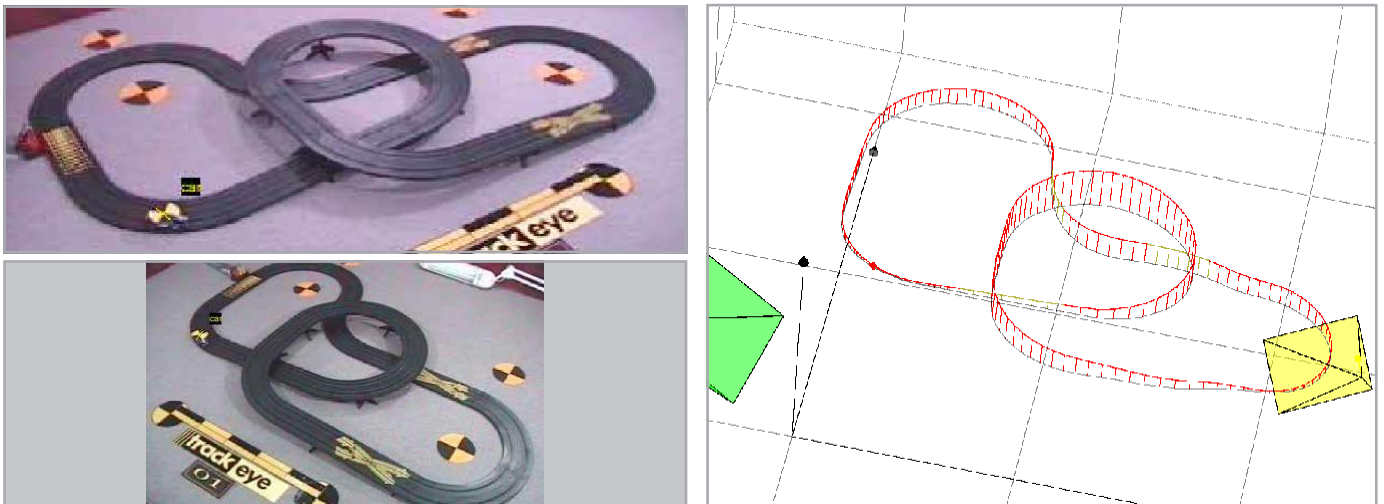

image
SYSTEMS

TEMA Classic3D

3D tracking of the firing of a portable missile launcher represents an advanced application. Trajectories and angles of missile are key data to assess the quality of ejection and ignition.

TEMA Classic 3D contains various algorithms to overcome complicated situations with up to 0.01 pixel accuracy. While dynamic camera orientation allows the user to correct for the vibrations of the camera during launching, a dynamic 3D coordinate system allows to create a reference frame attached to the projectile.



In TEMA 3D Analysis, the tracking algorithm is so robust that the marker can be tracked steadily even though it's frequently masked.

As long as two cameras or more are oriented in the same 3D coordinate system, any target visible in at least two camera views will have its position calculated in 3D.

TEMA takes the tracked pixel coordinates from each camera, computes the direction from each camera to the target, and triangulates a 3D-position,

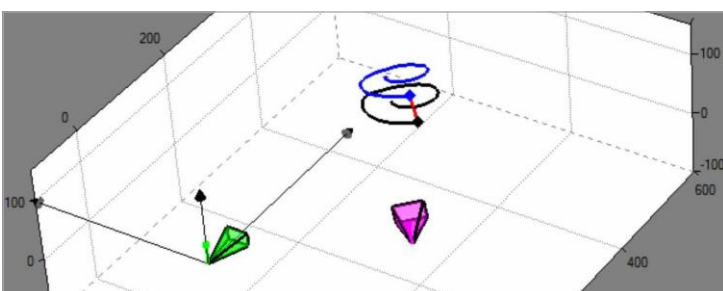
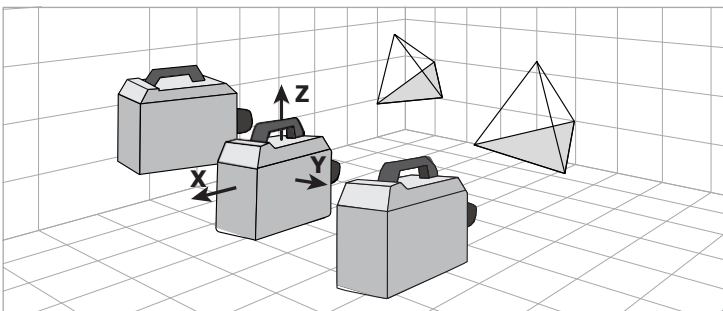
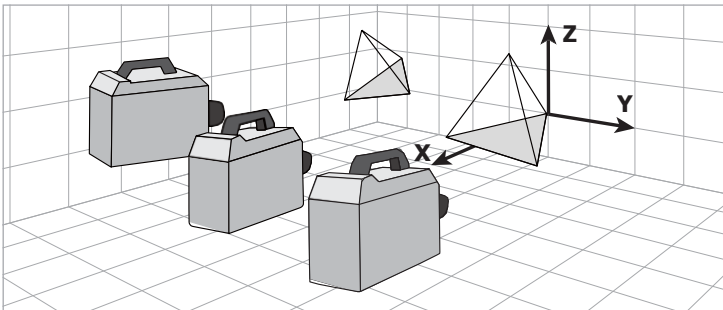

Exportable 3D Data

- Distance • Displacement • Velocity • Acceleration • Angle • Angular speed ... regarding default/customized 3D coordinate, can be exported as time tables, point tables, (multi-axis) diagrams, 3D diagrams with raw or filtered trajectories.

Static / Dynamic Camera Orientation

- By default, 3D coordinate system is extracted from the survey file (can be edited using 3D tracked points).
- Higher accuracy with well surveyed references;
- Capable of compensating for movement of the cameras or calculate trajectories of objects relative to each other.

Relative Camera Orientation

- Default 3D coordinate system attached to the primary camera (can be edited using 3D tracked points) ;
- For more than two camera views, they should be calculated in pairs;
- Higher flexibility easily identifiable points;
- Suitable for quick tests or tests without well surveyed references.

3D Wand (Optional)

- Fastest and most automated
- Calibrate all cameras (≥ 2) simultaneously with:
 - ✓ Lens Distortion
 - ✓ Camera Orientation
- Generate accuracy report

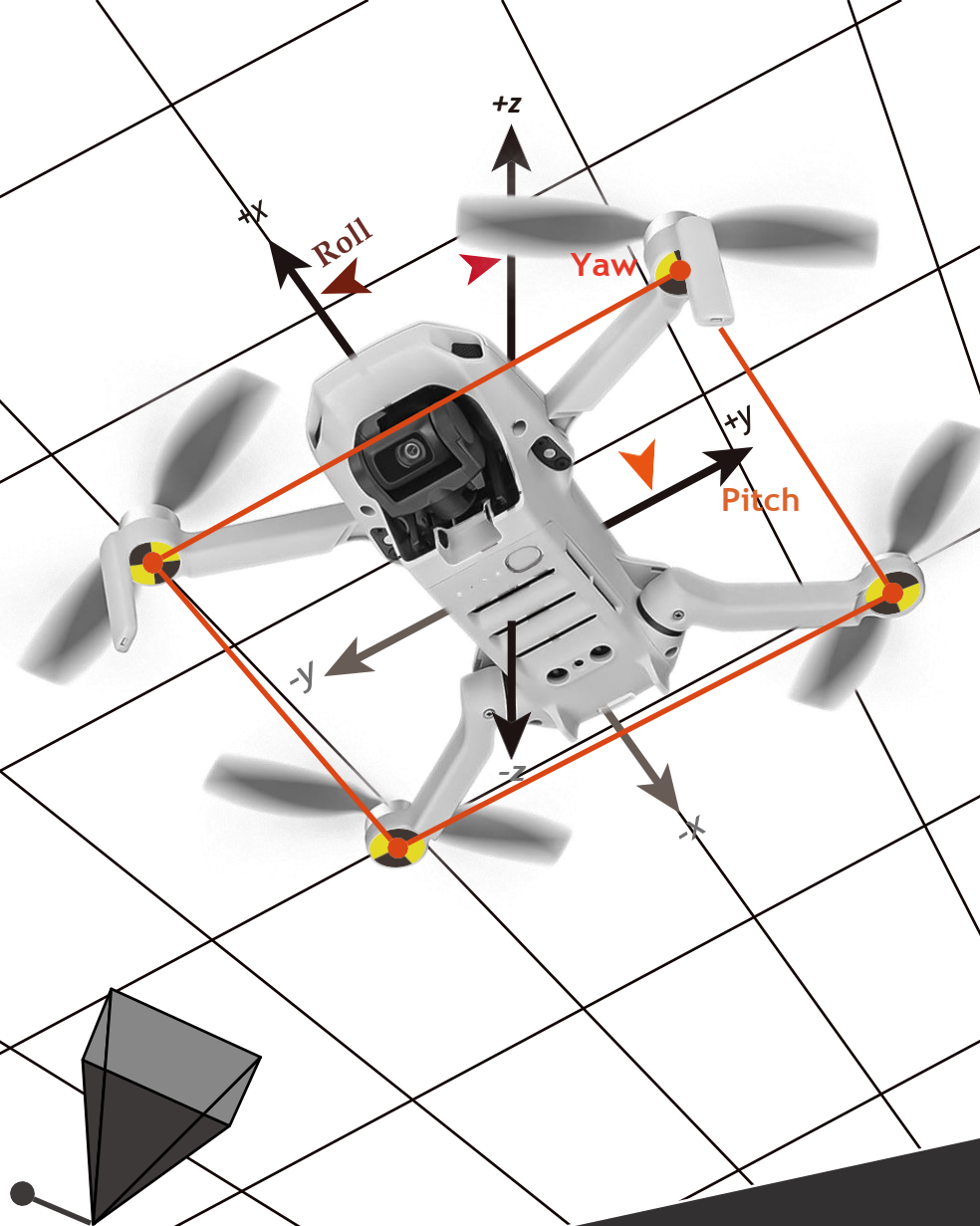
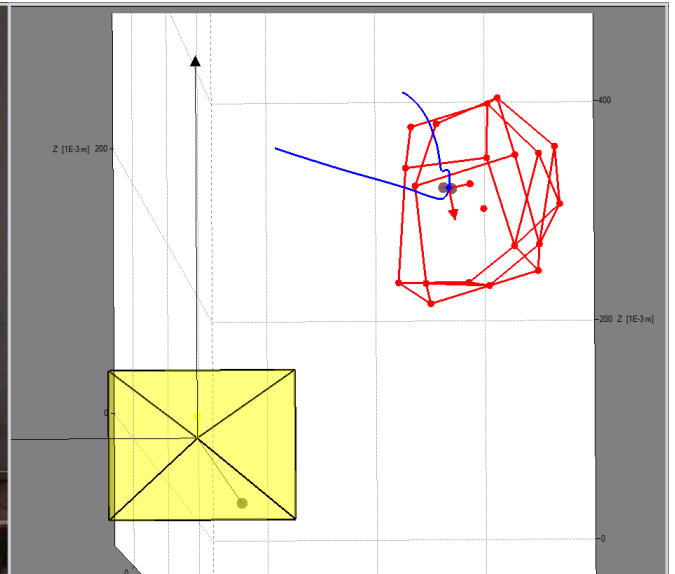

image
SYSTEMS

TEMA Classic 6DoF

Hovering test of a drone flying in strong wind conditions. 6DoF tracking of the rigid body of the drone in TEMA enables accurate measurements and complete understanding of the drone's behaviour.

TEMA Classic 6DoF provides a flexible and cost efficient solution. The 3D trajectory, velocity, acceleration and 3D orientation (roll, pitch, yaw) of the drone will be calculated using a single camera view.



The orientation and 3D movement of the surveyed dummy head is measured by TEMA Classic 6DoF with single camera view.

Tracking in 6 degrees of freedom (6DoF) is an optional feature of TEMA that computes the position and orientation of a rigid tracked object.

The operator must define target models containing well-defined points with 3D coordinates in the objects' own coordinate system. The targets must be rigid structure where individual points are not moving relative to each other, typically a seat, a dummy head, etc.

The TEMA Classic 6DoF calculation is not only for the origin of coordinate system attached to rigid body, but also 3D positions for other points of the model.

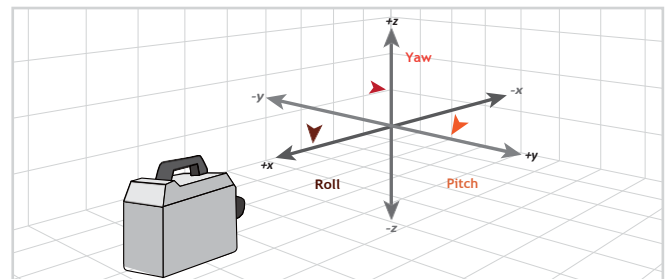

Result Presentations

- Time tables with position and orientation data
- Diagrams with position and orientation curves
- 3D diagram with the trajectory and stick figures of the tracked object

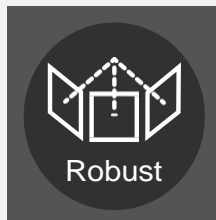

- Single camera view solution;
- 3D position (x, y and z), trajectory and 3D orientation (roll, pitch and yaw) measurement for rigid body;
- Only 4 visible points (more recommended) on an object are required under harsh conditions;
- Implementable virtual point function - the 3D data of invisible or untracked points belonging to the survey of the rigid body structure can be calculated as long as at least 4 points of the same rigid body are tracked.



- Cost efficient 6DoF measurement for rigidbody;
- 2 options are available in TEMA 6DoF for specifying the coordinate system to be suitable for a variety of applications,
 1. Target System at t0
Reference Target Coordinate System at t=0
 2. Camera System
The 6DoF algorithm measures the object's position and attitude relative to the camera position.

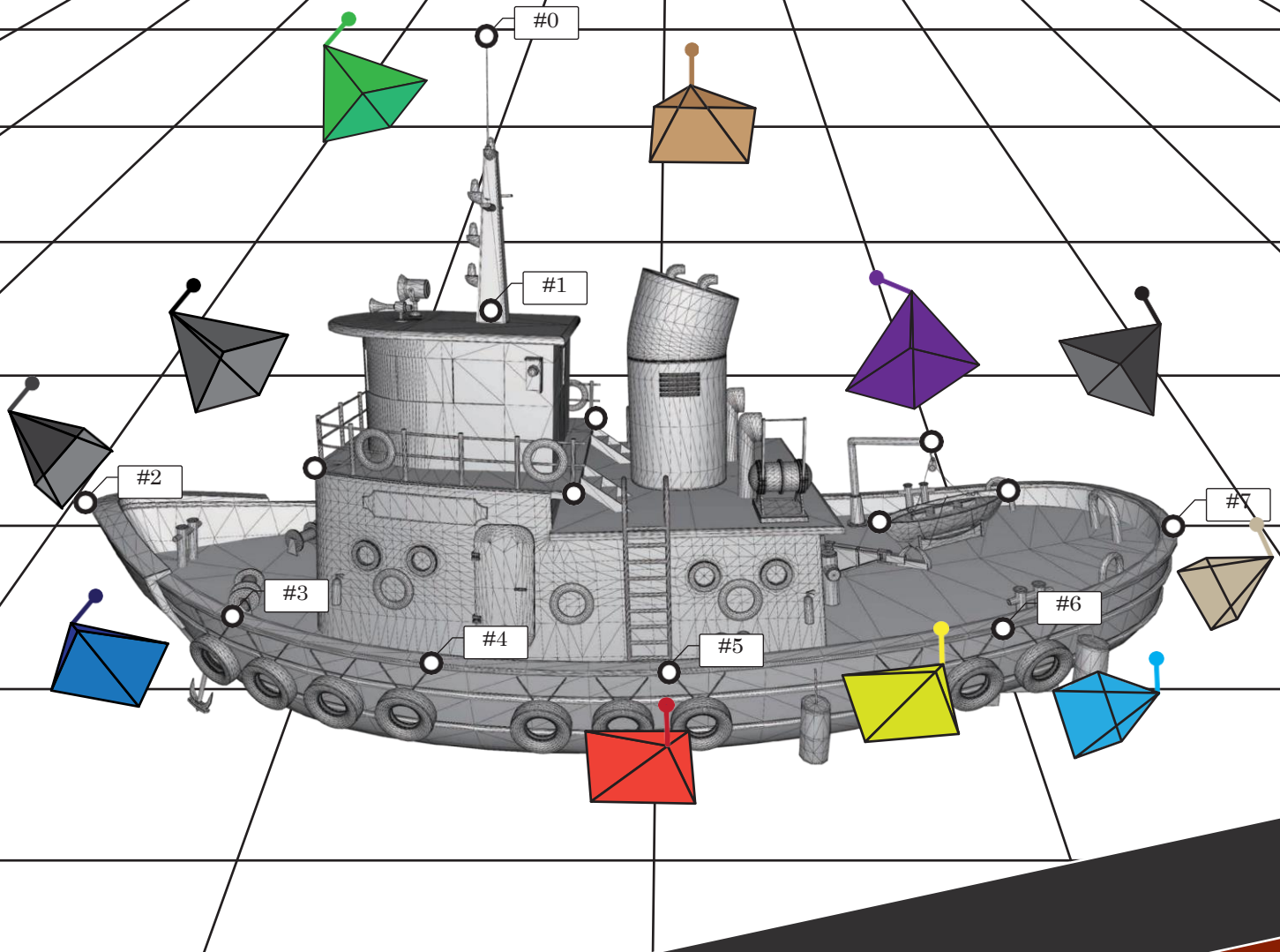

image
SYSTEMS

TEMA Static 3D

6DoF study for an object floating in artificial waves is a classic application in Marine Engineering. To be able to analyze the object with TEMA 6DoF, a 3D-target containing surveyed points are needed.

TEMA Static 3D is a fast survey toolkit to capture multiple images of the boat, and calculate the 3D positions of surveyed points based on Photogrammetry.

Static 3D is a powerful software tool capable of generating 3D models and measurement data - from static objects and environments - using still imagery. Measurement points can be manually selected in the images, or automatically identified using markers.

Manually selecting points in the images allows the operator to retroactively derive measurement data from the images, even if markers were not placed.



Using the calibrated camera from the system, the operator captures a series of images of a target object or environment to be measured.

At least six common points (more recommended) should be visible by pair of images. The points could either be quadrant markers, hand drawn markers, or shapes/contours of the object. Finally, one physical distance (acting as scale) between two points must be known to complete the process.

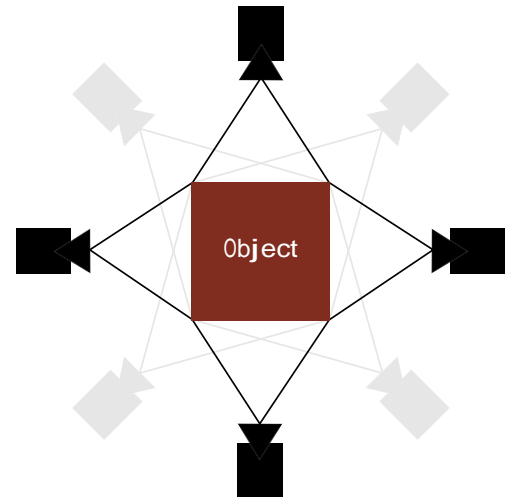

Key Features

- High precision 3D modelling;
- Flexible for large scale object measurements;
- Cost-effective with DSLR camera & prime Lens;
- Retroactive measurements;
- Various export formats (DDXF, ASCII, CSV files, CAD software export, etc.)

The software wizard will then generate the X, Y, Z data of markers and/or manually selected points and create a 3D target model.

The data of the Target Model can be visualized in a point table (X, Y and Z) as well as in a 3D diagram for verification purposes.



Point	Status	Views	x (cm)	y (cm)	z (cm)	parallel (cm)	From	To	Distance (cm)
1	Adjusted	6	17,267	-3,265	-3,459	0,00213	24	25	9,662
2	Adjusted	5	18,382	-0,017	-3,820	0,00972	32	33	9,727
3	Adjusted	6	17,352	3,354	-3,432	0,00732			
4	Adjusted	5	13,689	5,317	-2,088	0,00159			
5	Adjusted	7	13,287	2,834	-1,706	0,00327			
6	Adjusted	6	13,329	0,038	-1,916	0,00339			
7	Adjusted	6	13,308	-2,798	-1,816	0,00197			
8	Adjusted	5	13,552	-5,476	-2,285	0,00182			
9	Adjusted	6	11,474	-4,144	-1,651	0,00262			
10	Adjusted	8	7,372	-3,225	-0,187	0,00442			
11	Adjusted	9	7,429	2,975	-0,108	0,00353			
12	Adjusted	7	11,380	3,974	-1,499	0,00368			
13	Adjusted	10	0,000	0,000	0,000	0,00346			
14	Adjusted	7	1,341	3,138	0,111	0,00463			
15	Adjusted	6	-2,065	-5,238	-1,201	0,00646			
16	Adjusted	7	-0,943	6,105	-0,961	0,00395			

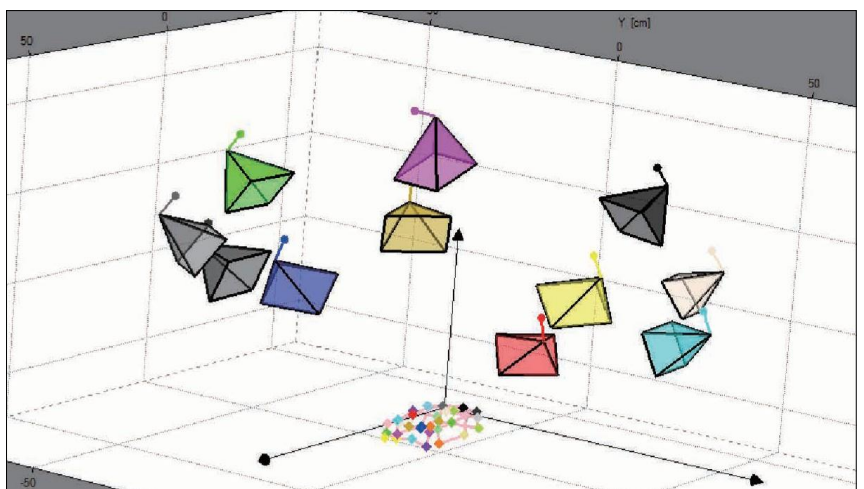

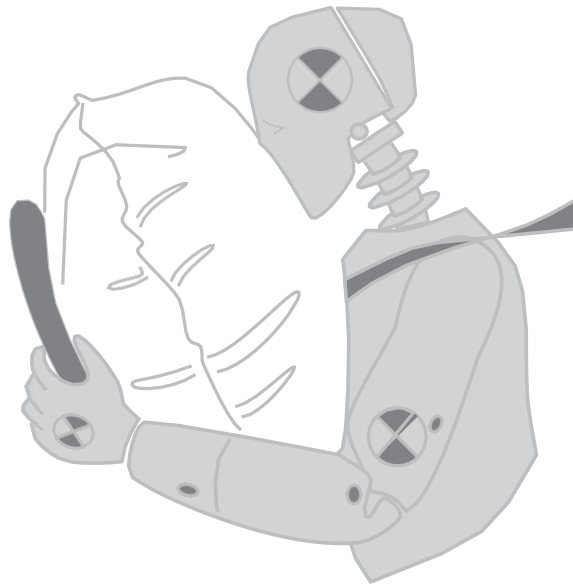

WHEN MOTION COUNTS

TEMA Classic

Authorized Distributor

Dynamic Analysis System Pte Ltd (Singapore)

Block 3015A, Ubi Road 1, #05-06, Singapore 408705. Tel: +65 6747 6883

Email: sales@photonics.com.sg Website: www.photonics.com.sg

Dynamic Analysis System (Thailand) Co., Ltd

4345 Bhiraj Tower, 23th Floor Sukhumvit Rd, South Bangna, Bangkok 10260 Thailand

Email: sales@photonics.com.sg Website: www.photonics.com.sg